

Viper deLuxe

Tour version

Manufactured for
Look – SOLUTIONS MADE IN GERMANY



powerful output

strong fan

Flightcase on wheels

Made in Germany

The **Viper deLuxe** unites a powerful 2600 Watt fog generator and a fan with 400 Watt in a robust flightcase.

A powerful fog output and simple handling are the advantages of the machine.

With a diverter the direction of the output can be changed. Due to this the fog can be fast distributed within a room.

Features

- Control panel

The control panel with LED-display, simple symbols allow for easy operation. It also protects the control buttons against dirt.

- Finest adjustments of the output

Digital technology makes fine adjustment of the pump possible. In steps of 1% the output can be adjusted from 0 - 99%.

Thus, any desired effect from a tiny fog-cloud to the thickest fog can be produced.

The fan can be adjusted separately from 0 - 99%.

- DMX 512 as standard

The **Viper deLuxe** can be controlled via *DMX 512*. The connection is done with 5pin-XLR-plugs.

The DMX start address can be adjusted and saved via the control panel.

The fan can be controlled via DMX on a second channel as well.

The machine then needs two channels on the desk.

The machine can also be controlled with *analog (0 - 10 V)* via a lighting desk or via XLR-remote (option). This connection is done with 3pin-XLR-plugs.

The pump – and therefore the output – can be adjusted with the XLR-remote or via an analog desk, the adjustment of the fan is done directly at the machine.

A *stand-alone-mode* is also possible. The adjustments are done directly at the machine. A short press at the start button makes the machine run. Therefore a permanent pressing of the start button is unnecessary.

- Internal timer

With the internal timer the fog time can be exactly adjusted in seconds, the wait time in minutes and the output in %.

- Flightcase

The case on wheels protect the machine and the fan, guarantees easy handling and make a flexible use possible.

Four handles for easy transportation.

The lids in the front and the back are fixed with butterflys and can be quickly unscrewed. Thus the control panel and the tank housing, which is fixed on the floor, can easily be reached.

Fluid

The following Look-fog fluids are available for the **Viper deLuxe**:

- Quick-Fog (thick, quick disappearing fluid)
- Regular-Fog (thick, long lasting fluid)
- Slow-Fog (thick, extremely long lasting fluid)

Technical data fog generator

Procedure	vaporizing fog generator
Power requirement	2600 Watt
Voltage	230V/50Hz
Warm up time	approx. 7 min.
Fluid consumption at max. output at continuous output	240 ml/min. 70 ml/min.
Fluid tank capacity	5 liter
Fog output	adjustable in 99 steps
Output projection	max. 25 m
Fogging time at < 50% output	continuous output
Air quantity of the internal fan	adjustable in 99 steps
Control	DMX 512 0 - 10 V analog Stand-alone-Mode Radio remote (Option)
Temperature control	Microprocessor controlled
Overheating protection	Heater block/Thermostat Pump/Thermal switch
Dimensions (L x W x H)	75 x 42 x 77 cm
Weight with case & fan	approx. 46.7 kg

Advantages

- Fog and air in one case
- DMX as standard, analog and Stand-alone-Mode
- Internal timer
- Powerful output (up to 25 m)
- Internal, powerful fan
- Fog and air output adjustable in 99 steps
- Continuous output
- Easy handling
- Compact
- Flexible use
- Made in Germany

Accessories

- Duct adaptor for hose Ø 100 mm
- XLR-remote
- Radio remote

Technical data fan

Procedure	Centrifugal blower
Voltage	230 V, 50 Hz
Air volume	1060 m ³ /h
Power requirement	355 Watt
Current	1,55 A
Capacitor (internal)	8 µ / 450 VDB

Dimensions

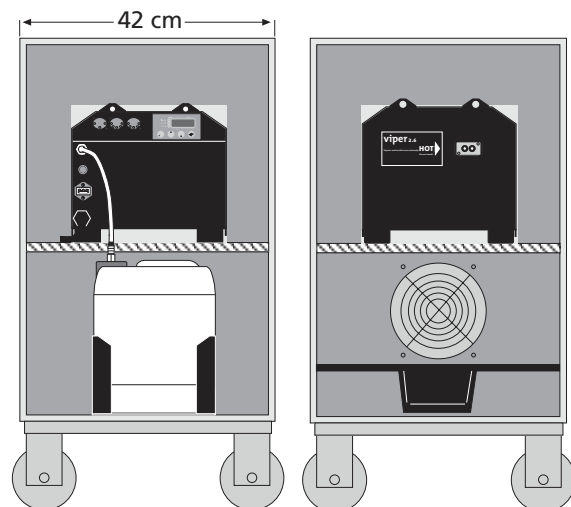
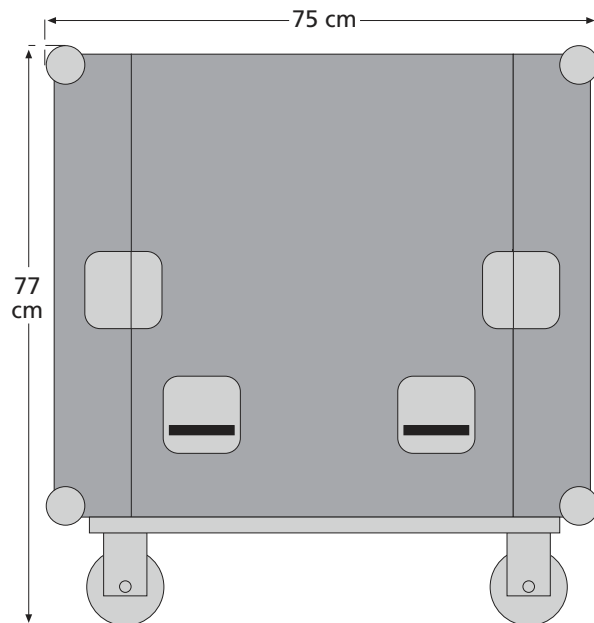

Service

Based on the strong partnership with the German manufacturer OTTEC Technology GmbH, Look Solutions is able to provide a quick and easy service which guarantees the high quality of all products.